

■ Keep your Volvo running in top shape by following these simple service tips:

Service Tips

Wheel Applications and Identification **Tip #1**

Lubrication of Door Locks **Tip #2**

Using the Service Label to Obtain the Correct
Parts **Tip #3**

Location of Relays-240/260 Series **Tip #4**

Painting Exterior Plastic Components **Tip #5**

Where Are the Fuse Boxes Located? **Tip #6**

Crankcase Ventilation **Tip #7**

Replacing The Timing Belt **Tip #8**

Battery Maintenance Tips **Tip #9**

Towing Tips for the V70 AWD (All Wheel
Drive) **Tip #10**

You can order your Volvo service literature from [Volvo Cars of North America Technical Information World Wide Web Page](#)

Tip #1

Next: Lubrication of Door Locks

Service Tips

Wheel Applications & Identification

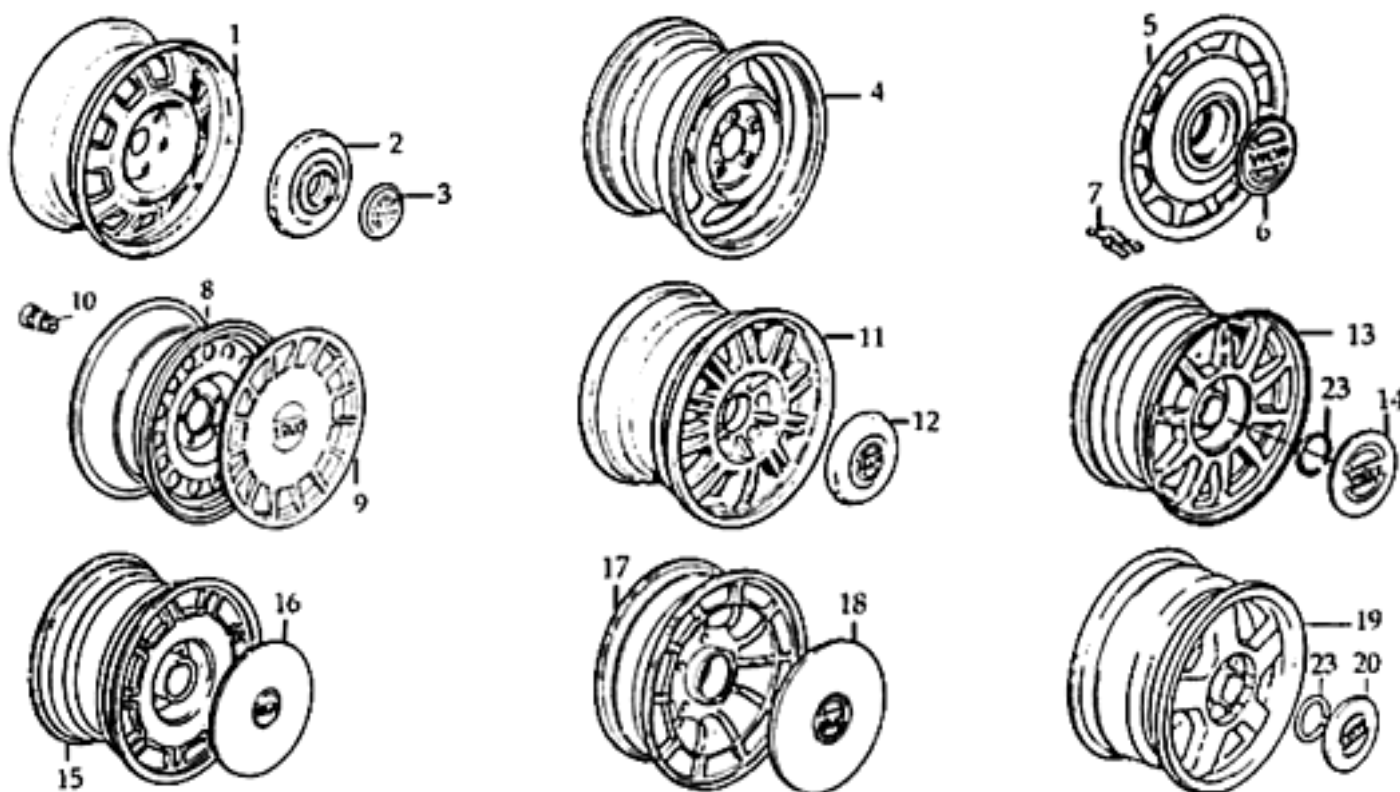

Fig.	Dimension	Year	Part Number	Notes
1	14 x 5.5"	1983-84	1272641-0	
1	15 x 5.5"		1273387-9	
2			1272643-6	For wheel 1272641-0
2			1272211-2	For wheel 1273387-9
3			1342290-2	For cap 1272643-6
3			1272790-5	For cap 1272211-2
4	14 xz 5.5"	1985-88	1273879-5	
5			1325912-2	
6			1325914-8	
7			1325913-0	

8	15 x 6 "		1387534-9	
9			1392530-0	
10			1359216-7	Valve extension
11	14 x 5.5"		1330475-3	
12			1272666-7	
13	15 x 6"		1229998-8	
13			1329603-3	Lacquered
14			1272666-7	For wheel 1229998-8
14			1325375-0	For wheel 1329603-3
15	14 x 5.5"	1983-86	1329915-1	
15			1387159-5	Lacquered
16			1325908-0	
17			1329835-1	
17	15 x 6"	1986	1387158-7	Lacquered
18		1987-	1325911-4	
19	15 x 6"		1330400-1	
20			1343663-9	
23			1325483-4	

NOTE: Ask your Volvo Retailer's Parts Department about wheel emblems.

| [Back to Service Tips](#) |
| [Next: Lubrication of Door Locks](#) |

Tip #2

Previous: [Wheel Applications & Identification](#)

Next: [Using the Service Label to Obtain the Correct Parts](#)

Service
Tips

Lubrication of Door Locks, 240 Models, All

Stiff opening of doors from inside and outside may be caused by lack of lubrication. The grease used in production, in extreme cases, may dry out. Recommended grease: low temperature grease. Other greases provide insufficient cold weather protection.

1. Remove Latchplate

Unscrew and remove both Allen screws.
Remove lock from door, taking care not to drop the inner part into door.

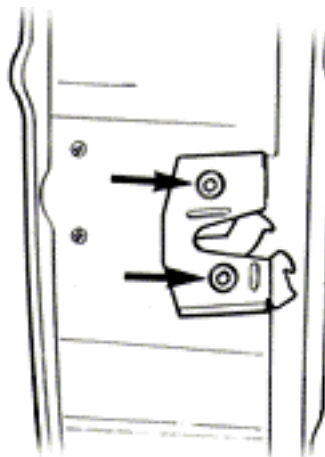

2. Engage Lock Position

Ease off plastic cover with a screwdriver.
Remove dirt and dried grease, etc.

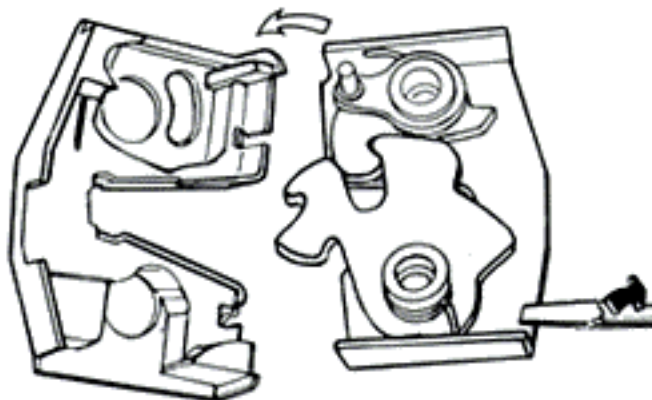

3. Smear parts with low-temperature grease.

Apply reasonable amount of grease to parts (A), arrowed. Refit cover and check that mechanism operates smoothly.

4. Install Lock

Check door alignment. If necessary adjust striker plate. Check function of lock.

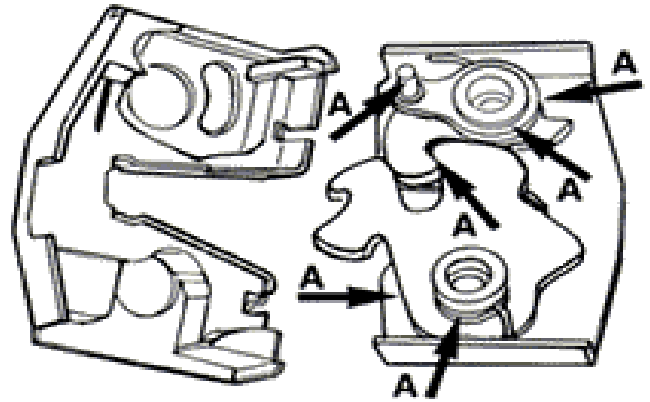

| [Back to Service Tips](#) |

[Previous: Wheel Applications & Identification](#) |

[Next: Using the Service Label to Obtain the Correct Parts](#) |

Tip #3

[Previous: Lubrication of Door Locks](#)

[Next: Location of Relays-240/260 Series](#)

Service Tips

Using the Service Label to Obtain the Correct Parts

The "Service Label" is attached to the body of every Volvo Sedan and Station Wagon. This label contains codes that identify the vehicle model and the type of body, chassis, engine, brake, fuel pump, clutch, alternator, and steering gear. Sometimes these codes are required by your Volvo Retailer Parts Manager to provide you with the correct Genuine Volvo Parts.

This label is on every Volvo and is located in a variety of places depending upon the year and model. Look for this label on the rear cargo/trunk area, on the door pillar, or inside the engine compartment on either a shock absorber tower or radiator support panel.

The codes assist in the correct identification of parts needed to complete maintenance or a repair. For instance, it is necessary to identify the type of brake calipers on the car to order brake pads. The code "1" or "2" on the Service Label identifies the type of calipers on the car.

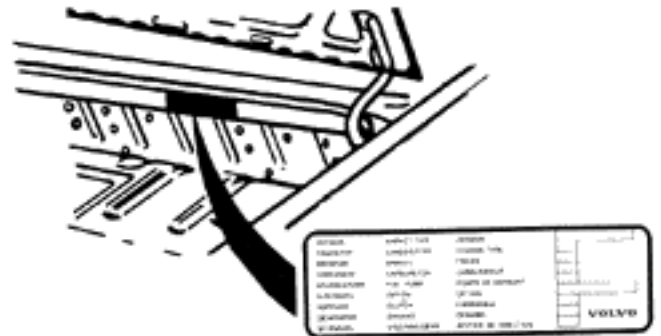
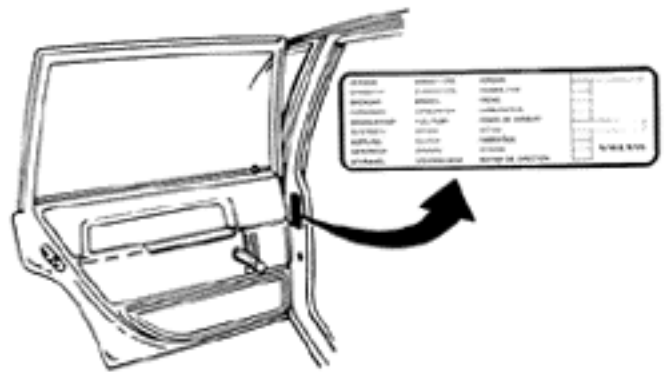

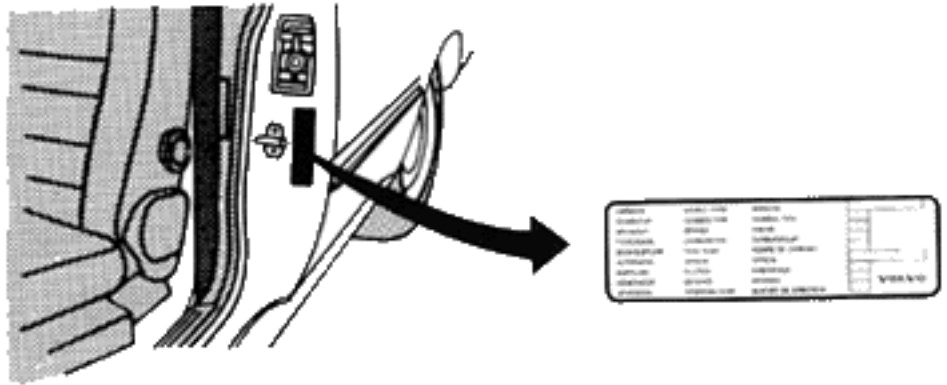

| [Back to Service Tips](#) |
| [Previous: Lubrication of Door Locks](#) |
| [Next: Location of Relays-240/260 Series](#) |

Tip #4

Previous: [Using the Service Label to Obtain the Correct Parts](#)

Next: [Painting Exterior Plastic Components](#)

Service Tips

Location of Relays-240/260 Series

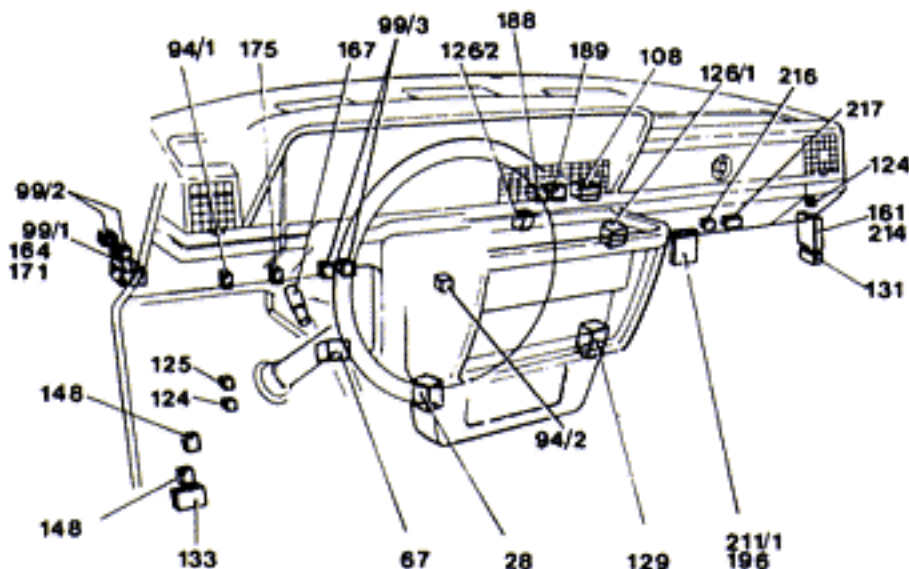

The drawings of relays and control units in the illustrations are for location only, not size or shape.

<u># Key</u>	<u>Description</u>	<u># Key</u>	<u>Description</u>
2	Terminal board	156	Auxiliary light and foglamp relay
9/1	Voltage regulator	159	Oxygen sensor (Lambda Sond ®) relay, - 85
13	Stepping relay for low beams, high beams and flasher	161	Emission control system control unit, -85
28	Direction indicator relay	164	Glow plug relay, D24, with integral 80 A fuse
67	Light warning buzzer, - 80	165	Glow plug relay, D24, 84-
80	Headlamp wiper relay, 80 -	167	Time delay relay, interior lighting
94/1	Seat belt reminder, (USA)	168	Electric radiator fan, - 85
94/2	Seat belt reminder, 80-	171	Direction indicator control unit, - 86
99/1	Fuel pump relay, - 79	175	Rear window heater relay, USA, -89
99/2	Fuel pump relay, - 76/77	188	Central locking relay, opening
99/3	Fuel pump relay, - 75	189	Central locking relay, closing
		196	Rex ignition system control unit

104/1	Ignition system control unit.	210/1	TZ-28H ignition system control unit
104/2	Ignition system control unit, TSZ-04/TSZ-2 (260), 85-	210/2	Chrysler ignition system control unit
108	Overdrive relay	210/3	Control unit relay, diesels, 80-
124	Main lighting relay, - 85	211/1	EZ-116K ignition system control unit, - 89
125	Rear foglamp relay, - 86	211/2	Starting valve impulse relay, - 85
126/1	Power window relay, - 80	212	In-line fuse for emission control system
126/2	Power window relay, - 84	214	Control unit, LH emission control system
129	Air conditioning relay	214	Control unit, LH emission control system
131	CIS control unit, - 85	216	Fuel pump relay, 84-
133	Dim-dip regulator (GB)	216	Fuel pump relay, 84-
148	Windshield wiper intermittent relay	217	Main relay for LH emission control system
153	Spotlamp relay, 80-	217	Main relay for LH emission control system
		230	Speed relay, - 85
		231	AC switch-out relay

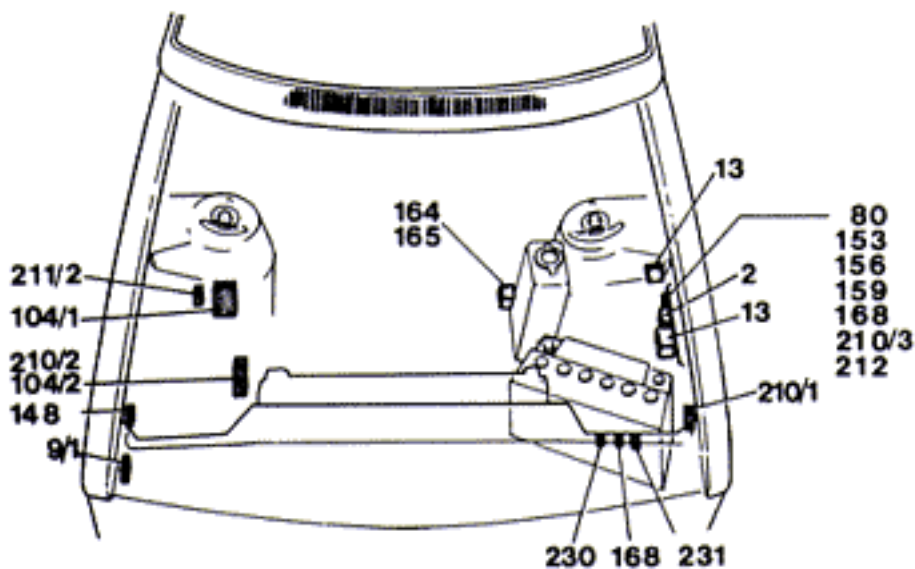

| [Back to Service Tips](#) |

| [Previous: Using the Service Label to Obtain the Correct Parts](#) |

| [Next: Painting Exterior Plastic Components](#) |

Tip #5

[Previous: Location of Relays-240/260 Series](#)

[Next: Where Are the Fuse Boxes Located?](#)

Service Tips

Exterior Plastic Components

The following is a list of the plastic components on a variety of Volvo models. Abbreviations in the listings state the type of material the component is made of.

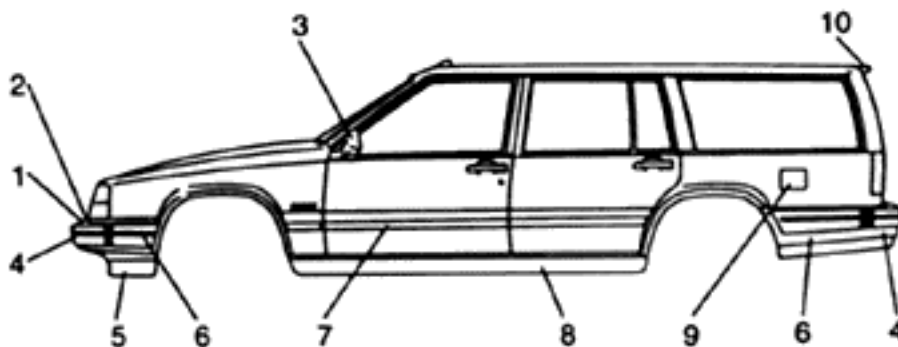

700/900 PLASTIC MATERIAL

Bumper Underside(4)	PP/EPDM	modified polypropylene
Bumper top side(2)	PP/EPDM	modified polypropylene
Side panel(6)	PP/EPDM	modified polypropylene
Spoiler(5)	PP/EPDM	modified polypropylene
Rear view mirror (3)	PPO/SB	polyfenyloxide
Gasoline cap (9)	PBT	polyamide
	P/PE polyester (740) up to and incl. 1990 models	
Strip under the headlights(1)	ABS	acrylonitrile butadene/styrene copolymer
Waist border (7)	PUR	modified polypropylene
Door handle 4/5 doors	PA	(reinforced glass fibre)
Hatch spoiler (10)	PUR	
Bottom swells (8)	PP/EPDM	modified polypropylene
	(740 and 760 up to incl. 1987 models) modified PA (760 from 1988 models.)	

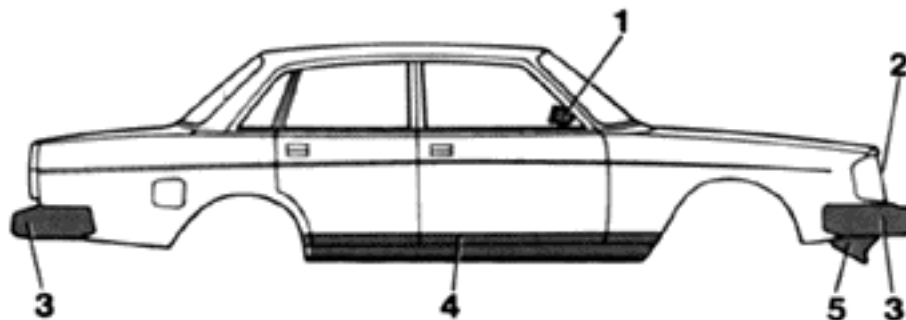

200 PLASTIC MATERIAL

Bumpers (3)	PP/EPDM	modified polypropylene
Spoilers (5)	PP/EPDM	modified polypropylene
Rear view mirror (3)	modified PPO	polyfenyl oxide
Door strip (4)	PVC	polyvinyl chloride
Grille (2)	ABS	acrylonitrile butadene/stryrene copolymer

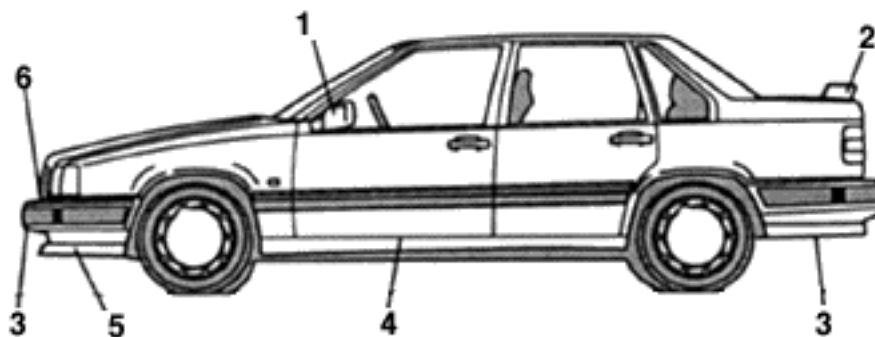

800 PLASTIC MATERIAL

Rear view mirror (1)	modified PPO (Noryl PX 1112)	Polyfenyl oxide
Spoiler (2)	modified PPO (Noryl BN 13)	Polyfenyl oxide
Bumpers (3)	PP/EPDM (approx. 30 rubber)	modified polypropene
Bottom swells (4)	PC/PBT (Xenoy CL101)	modified polypropene
Spoiler (5)	PP/EPDM (approx. 30 rubber)	modified polypropene
Strip under headlights (6)	PA/PPO	Polyamide/polyfenyloxide

| [Back to Service Tips](#) |

| [Previous: Location of Relays-240/260 Series](#) |

| [Next: Where Are the Fuse Boxes Located?](#) |

© [Copyright 1997](#) Volvo Cars of North America, Inc. All Rights reserved.

Tip #6

[Previous: Painting Exterior Plastic Components](#)

[Next: Crankcase Ventilation](#)

Service Tips

Where Are the Fuse Boxes Located?

SAMPLE INSTALLATIONS:

940: Install Fuse No. 5 and 26

The fuses (and relays) are located in the central electrical unit behind the ashtray in the center console.

To obtain access to the central electrical unit:

Remove the ashtray. Pull out and depress the tongue.

Press up the section marked "electrical fuses-press" and remove the unit.

There are 25 fuses, see diagram for fuse designated/locations.

When installing a new fuse, be certain to use the proper amperage fuse. Spare fuses are located on each side of the fusebox.

If you find it difficult to remove a fuse, you will find a special fuse tool clipped in the fuse box.

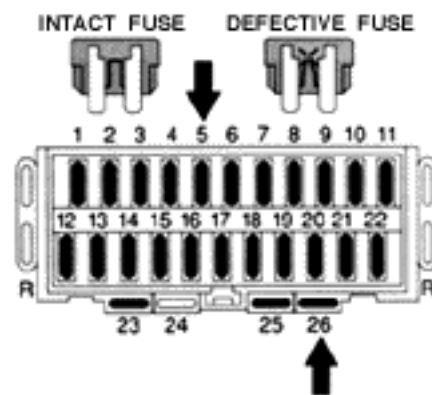
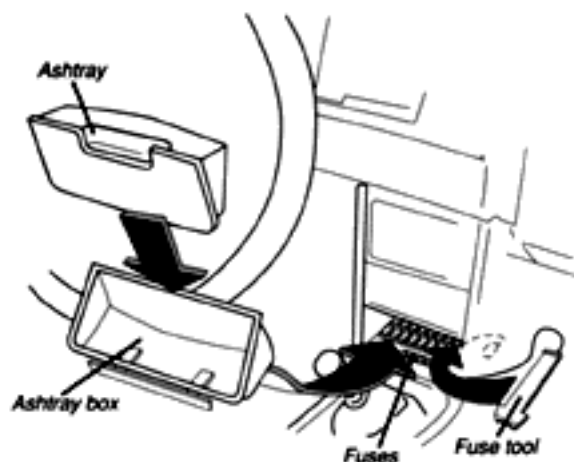

960: Install Fuses No. 2, 13 and 18

The fuse box is located on the far left side of the dashboard. Spare fuses and the fuse tool are located in an illuminated compartment in the fuse box.

To gain access to the fuses, remove the cover.

Install one 20 amp fuse (#2), one 10 amp fuse (13), and one 15 amp fuse (#18).

When replacing the cover, push in the front edge first and then press into place.

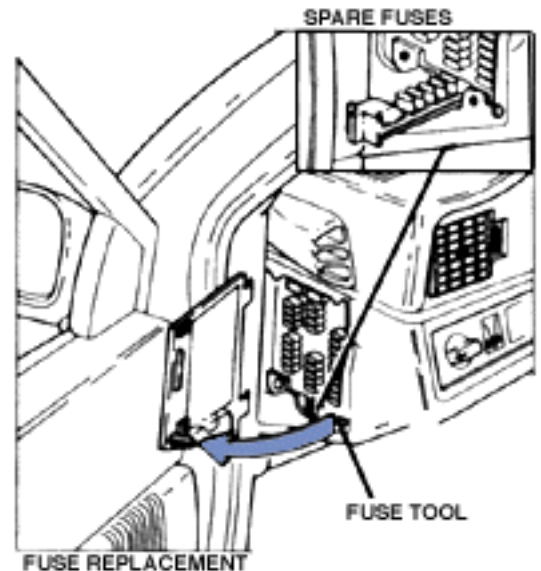

The easiest way to see if a fuse is blown is to remove it. Refer to the list of fuses on the inside of the fuse box cover to see which one should be examined.

If a fuse has blown, check the system that runs on that particular fuse.

Pull the fuse straight out. From the side, examine the curved metal wire to see if it is broken. If so, put in a new fuse of the same color and amperage (written on the fuse). Spare fuses are stored in a lit compartment in the fuse box:

- 1 x 15A (blue)
- 1 x 25A (pale yellow)
- 2 x 30A (green)

If you find it difficult to remove a fuse, you will find a special fuse tool clipped in the fuse box.

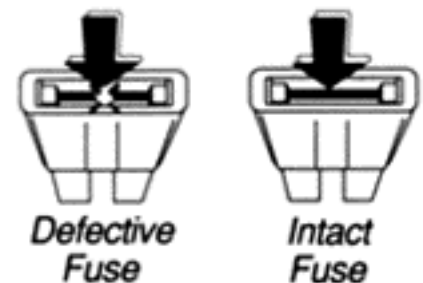

850 MODELS:

850: Install Fuses No. 6, 7, 15 and 17

The fuse box is located in the engine compartment (see illustration) and can be opened by lifting the cover (#1 in illustration).

Install a 25 amp fuse in number 6, a 10 amp fuse in number 15 and 17, and a 15 amp fuse in number 7. Spare fuses are located in the cover.

A label on the inside the cover indicates the amperage and the electrical components that are connected to each fuse.

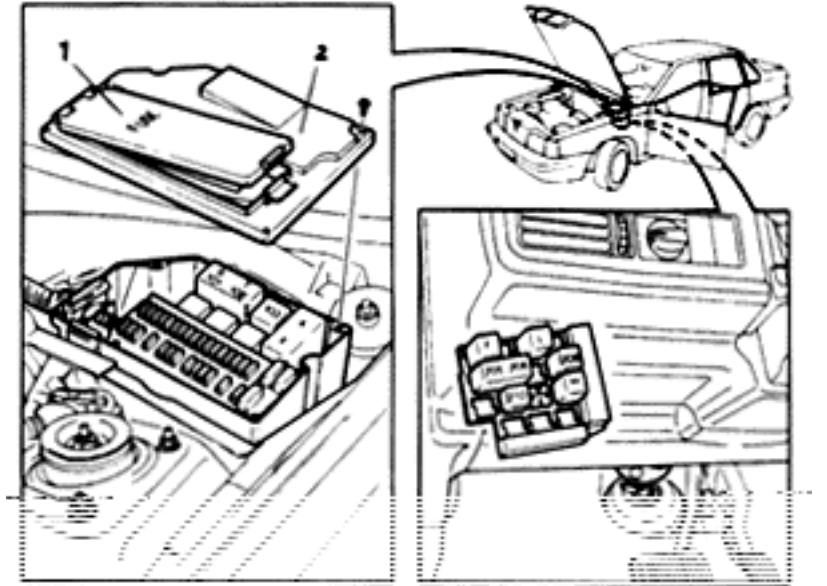

| [Back to Service Tips](#) |

| [Previous: Painting Exterior Plastic Components](#) |

| [Next: Crankcase Ventilation](#) |

Tip #7

[Previous: Where Are the Fuse Boxes Located?](#)

[Next: Replacing The Timing Belt](#)

Service Tips

Crankcase Ventilation

1) A clean flame guard is important to your non-turbo Volvo. Positive crankcase ventilation

- Inspect flameguard at stated intervals.
- Check hoses and nipples for condition and clogging. (failure to do so can result in loss of oil)

2) Turn flame guard cover (approx. 4/16", 15mm) to the left to remove.

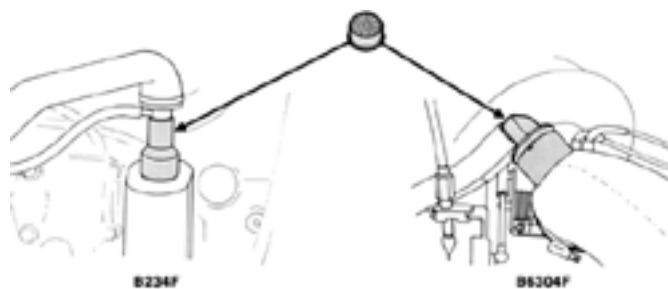

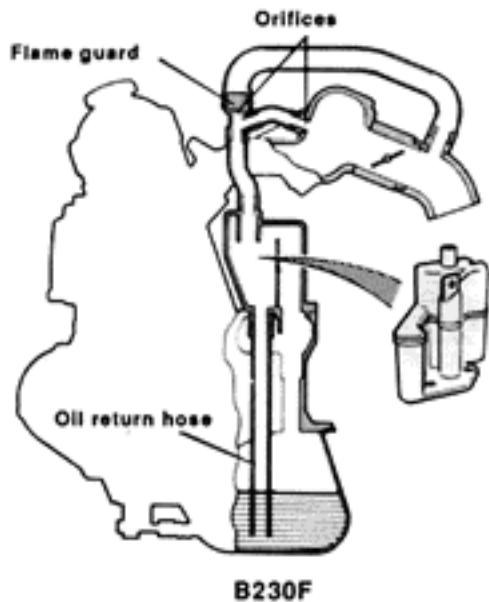

For B230FD: (1994 & newer 4-cylinder non-turbo models)

- Check condition of cover and check for clogging
 - Clean nipple and inlet manifold
 - Inspect flame trap (Turbo has no flame trap)
- Flame trap should be positioned in T piece.

| [Back to Service Tips](#) |

| [Previous: Where Are the Fuse Boxes Located?](#) |

| [Next: Replacing The Timing Belt](#) |

Tip #8

[Previous: Crankcase Ventilation](#)

[Next: Battery Maintenance](#)

Service Tips

Replacing the Timing Belt B230FD & B230F-TURBO (EGR)

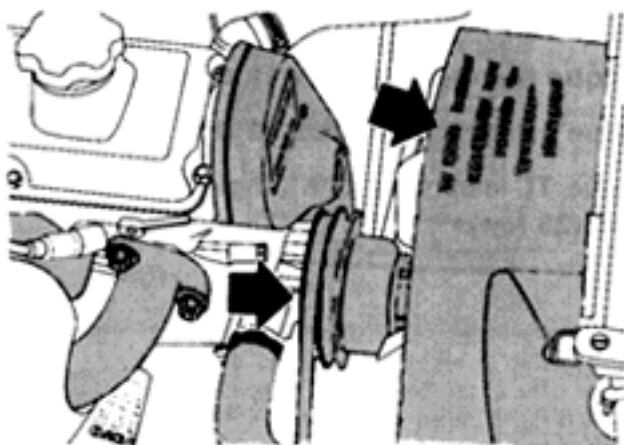

(1994 & newer, 4-cylinder, overhead camshaft, non-turbo & turbo sedans and wagons)
Check your owner's manual for the recommended replacement interval.

Preparations:

Remove engine cooling fan (FC and fan shroud, clips for preheater hose, drive belts and upper timing belt cover.)

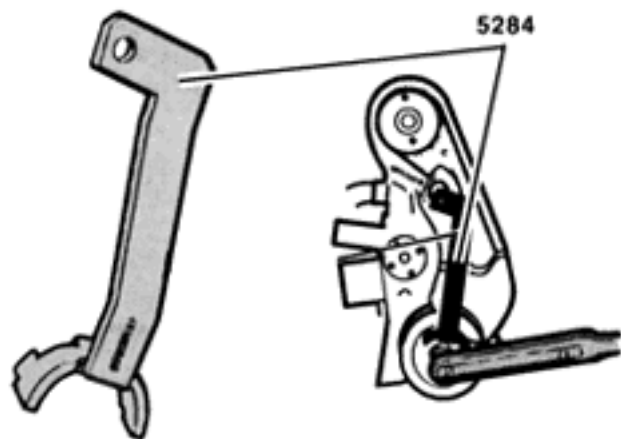

Special Tool:

Use special tool 5284 to hold when removing crankshaft pulley.

- Remove tensioner nut and washer.
- Attach tool 5284 to tension stud.
- Use tensioner nut (no washer) to hold tool 5284.

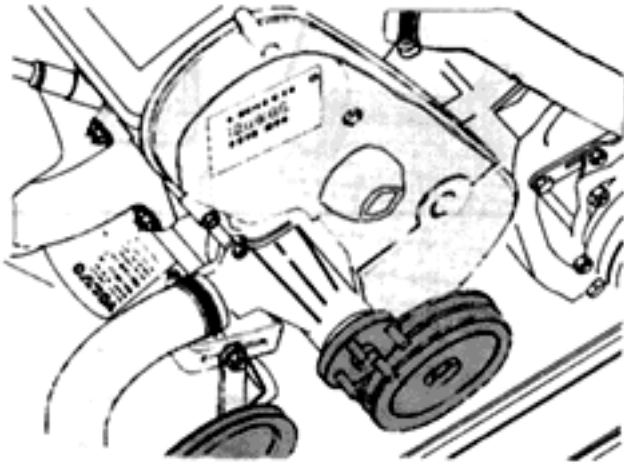

Remove:

- Crankshaft pulley and vibration damper assembly.
- Lower timing belt cover.

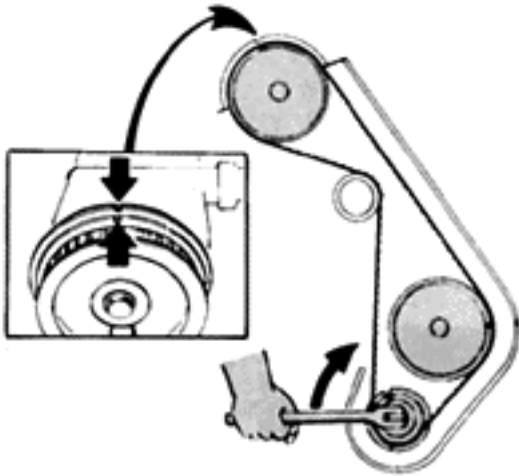

Line up engine:

- Use crankshaft center bolt to turn engine.
- Set mark on camshaft pulley toward mark on valve cover.

IMPORTANT!

Do not turn crankshaft or camshaft with timing belt removed.

Pistons and valves will collide.

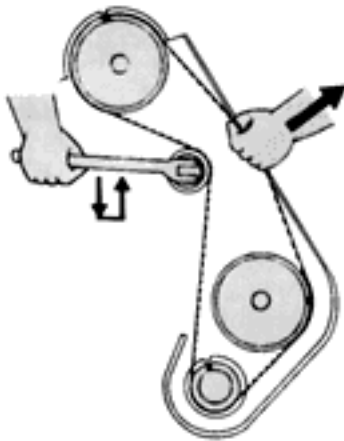

Remove Timing Belt:

- Loosen tensioner nut approx. 1 turn.
- Pull belt to compress tensioner spring.
- Tighten tensioner nut.
- Secure spring tensioner by appropriate drill, or similar, through hole in tensioner bolt.

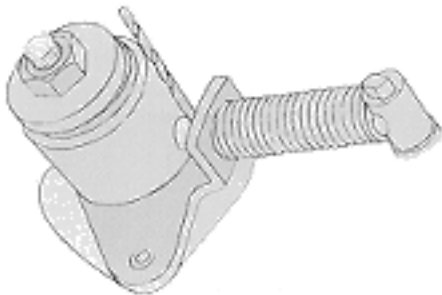

Check Tensioner:

- Check tensioner roller bearing.
- Check tensioner roller.
- If roller surface is damaged, roller as well as timing belt must be replaced.

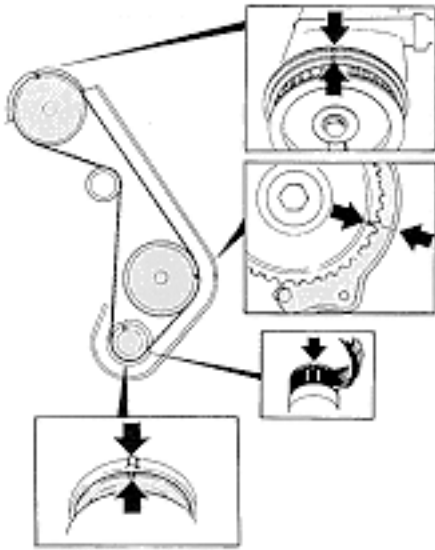

Check that engine is correctly lined up:

IMPORTANT!

Do not turn crankshaft or camshaft with timing belt removed. Pistons and valves will collide.

Install Drive Belt

First place timing belt on crankshaft sprocket and then on intermediate shaft sprocket. Two lines on timing belt should fit toward crankshaft marks.

Stretch timing belt on tension side and fit timing belt on camshaft sprocket and tensioner roller. Make sure timing belt is correctly installed and sprocket marks line up with marks on engine.

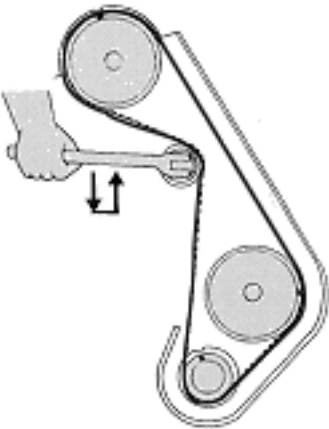

Tension timing belt:

Loosen tensioner nut approx. 1 turn to let it tension timing belt. Then tighten tensioner nut again.

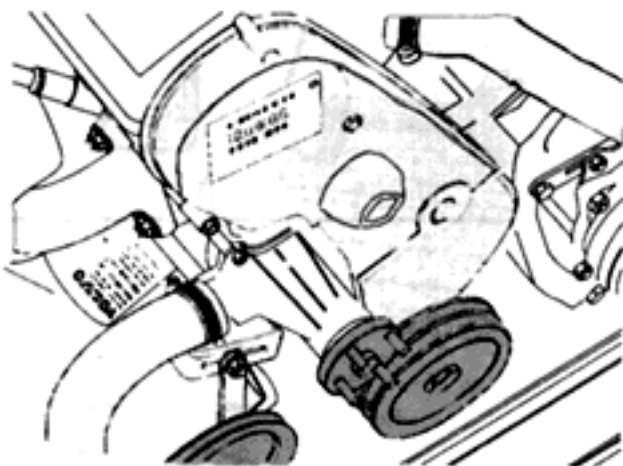

Install Timing Belt Covers:

Install crankshaft pulley vibration damper. Use special tool 5248 to hold.

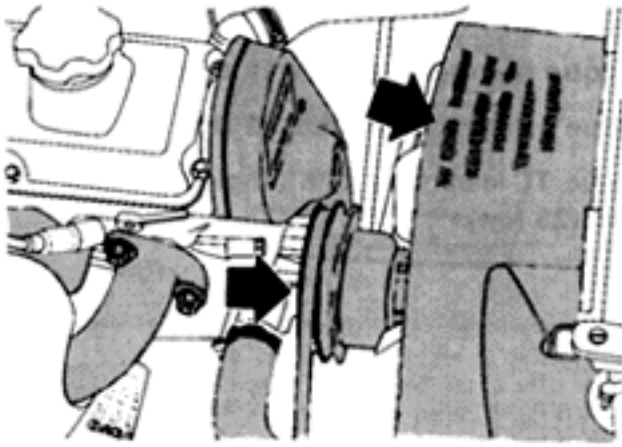

Install:

Install clips for preheater hose, fan, fan shroud and drive belts. Check that ignition timing is correct.

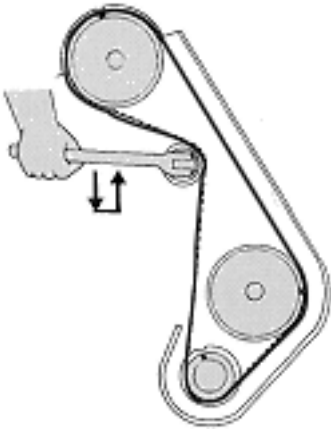

Run Engine

Run engine until it reaches normal operating temperature while checking operation. Then stop engine.

Readjust timing belt tension.

Remove rubber plug from cover. Release belt tensioner nut approx. 1 turn to let tensioner spring stretch timing belt. Rotate engine clockwise at least one half turn to top dead center (TDC) using crankshaft bolt.

Retighten nut and install rubber plug in cover.

| [Back to Service Tips](#) |

| [Previous: Crankcase Ventilation](#) |

| [Next: Battery Maintenance](#) |

Tip #9

[Previous: Replacing The Timing Belt](#)

[Next: Towing Tips for the V70 AWD](#)

Service Tips

Battery Maintenance Tips

Driving habits and conditions, climate, the number of starts, etc. all affect the service life and function of the battery. In order for your battery to perform satisfactorily, keep the following in mind:

- Check the fluid level in the battery every Six months or every 10,000 miles (16,000 km). The fluid level in each battery cell should be checked. Use a screwdriver to open the caps and a flashlight to inspect the level.
- If necessary, add distilled water to approximately 0.4 in. (10mm) above the plates in the cell, or to the level indicator. See illustrations.
- Check to ensure that the battery cables are correctly connected and properly tightened.
- Never disconnect the battery when the engine is running. For example when changing the battery.

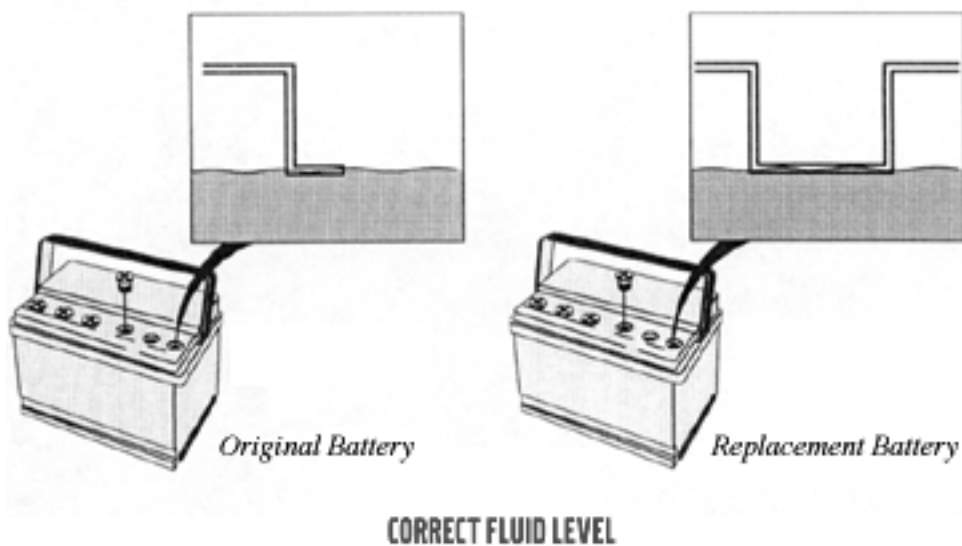

- The battery should be disconnected when a boost charger is used.
- Switch off the radio before disconnecting the battery. If your radio has an antitheft code and the battery is disconnected, the radio code has to be reentered in order for the radio to function.

| [Back to Service Tips](#) |

| [Previous: Replacing The Timing Belt](#) |

| [Next: Towing Tips for the V70 AWD](#) |

Tip #10

[Previous: Battery Maintenance](#)

Service Tips

Towing Tips for the V70 AWD (All-Wheel Drive)



All-Wheel-Drive cars must not be towed with only one axle raised.

Cars equipped with All-Wheel Drive must not be towed or transported with only one of the axles raised. Towing or transporting the car incorrectly will damage the viscous coupling which distributes power between the front- and rear-drive wheels.

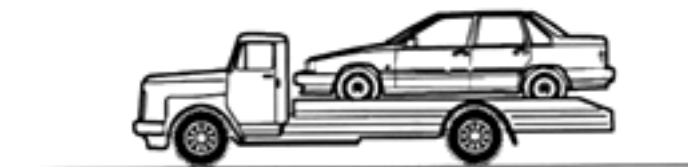

WARNING!

Do not use the towing eyelets on the car to pull the car up onto a flat-bed tow truck. The towing eyelets must not be used for pulling another vehicle out of a ditch or for any similar purpose involving severe strain.

| [Back to Service Tips](#) |

| [Previous: Battery Maintenance](#) |